

AD1100F Series
100Watts, Single Output



Dimensions: 121(D)x56(W)x110(H) mm

Features

- High power density
- Universal input range
- Convection cooled
- RoHS compliance
- 3 year warranty
- Great reliability
- DIN Rail / Wall bracket mounting solution
- Optional alarm signal / Redundant function
- Over voltage protection
- Overload protection
- Short circuit protection

Safety Standards



EN 60950 (Marking)



UL 508 (Certificate)
CSA 22.2 (Certificate)

EMC Standards

EN55011	Class B
EN55022	Class B
EN61000-4-2	Level 3
EN61000-4-3	Level 3
EN61000-4-4	Level 3
EN61000-4-5	Level 3
EN61000-4-6	Level 3
EN61000-4-8	Level 3
EN61000-4-11	Level 3

Model List

Model	O/P Voltage Adjustment	Loading Min.	Rated	Max.	Ripple Noise	Efficiency	Over Voltage Protection
AD1100-12F	+12VDC±10%	0A	8.0A	8.0A	100mVp-p	80%	15~17VDC
AD1100-24F	+24VDC±10%	0A	4.0A	4.0A	150mVp-p	81%	27~30VDC
AD1100-48F	+48VDC±10%	0A	2.0A	2.0A	250mVp-p	83%	52~56VDC

Model Encoding

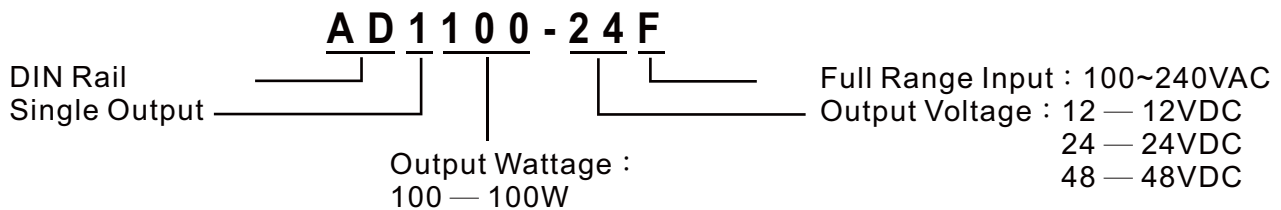

Specification

General	
Switching Frequency	85kHz
Isolation Voltage	Input-Output 3000VAC /4242VDC
	Input-FG 1500VAC/2121VDC
	Output-FG 500VAC/ 710VDC
Isolation Resistance	100MΩ when Input-Output @500VDC
Operating Temperature	-40°C~50°C ambient
Derating	2.5% per degree from 50°C to 70°C
Storage Temperature	-40°C to +85°C
Relative Humidity	5%~95% RH, Non-condensing.
Temperature Coefficient	±0.04% of output voltage per °C
MTBF	60,000hrs Min. Per MIL-HDBK-217F, 25°C GB
Attitude During Operation	2000m
Installation position	Vertical
Vibration	Random Vibration, 10~500Hz. 3 axis
Input	
Input Voltage	100~240VAC/120~370VDC
Input Frequency	47~63Hz
Inrush Current (cold start)	22A/115VAC 44A/230VAC
Rated Input Current	2.5A Max., Vi=100~240VAC
Leakage Current	Input-output 0.25mA, Inout-FG 3.5mA, Vi=250VAC
Output	
Output Voltage accuracy	±1%
Minimum Load	0%
Line Regulation	±1%, measuring from low line to high line rated load
Load Regulation	±1%, measuring from 20% to 100% of rated load 230VAC input
Voltage Trim Range	±10%(Min.)
Rated Continuous Loading	8A@12VDC, 4A@24VDC, 2A@48VDC
Hold Up Time	20mS Min., Full load@230VAC.
Turn On Time	1300mS
Rise Time	13mS
Fall Time	25mS

Website: <http://www.acro-powers.com/>
 E-mail: service@acro-powers.com.tw
 Tel: +886-2-22675015 Fax: +886-2-22674939



Specification

Output		
Transient Response	Recovery Time	2mS, Load change 50% to 100%
	Voltage Deviation	5%, Load change 50% to 100%
Efficiency		See model list, measuring at rated load and 230VAC input
Ripple and Noise		See model list, measuring by using a 0.1 μ F/630V metalize capacitor and a 47 μ F electrolytic capacitor parallel on the test point, at rated load and 230VAC input.
Protection		
Input Fuse		3.15A/250V
Internal Surge Load Protection		Varistor, IEC6100-4-5
Degree of Protection		IP20
Short Circuit Protection		Autorecovery
Over Voltage Protection		Autorecovery
Rated Over Load Protection		160~200%
Overload protection		Power limited

Derating Curve

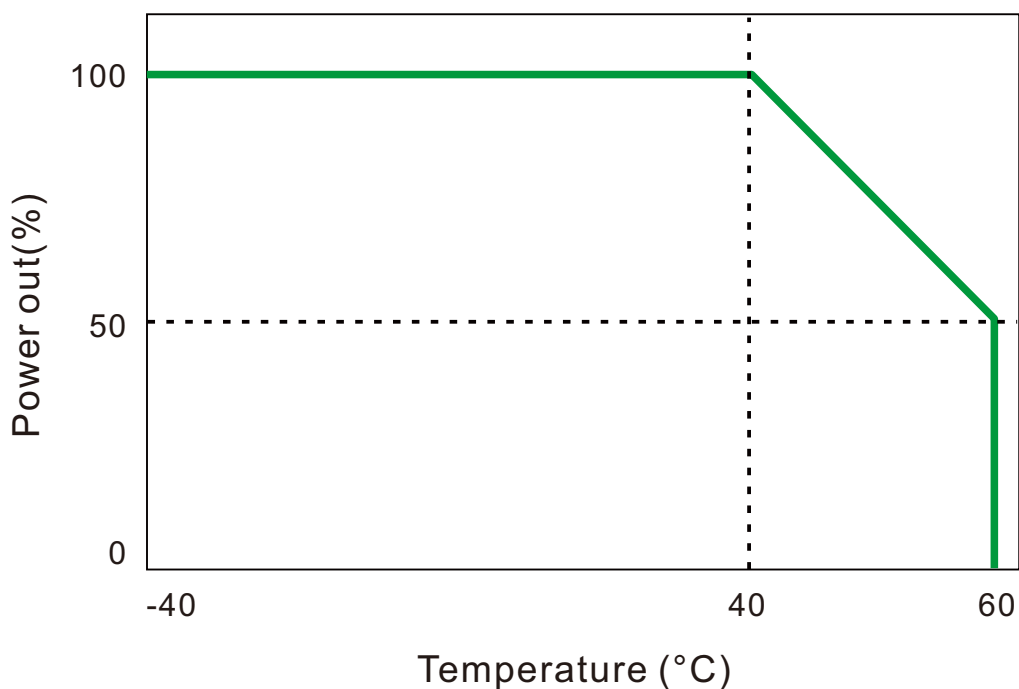

Mechanical Details

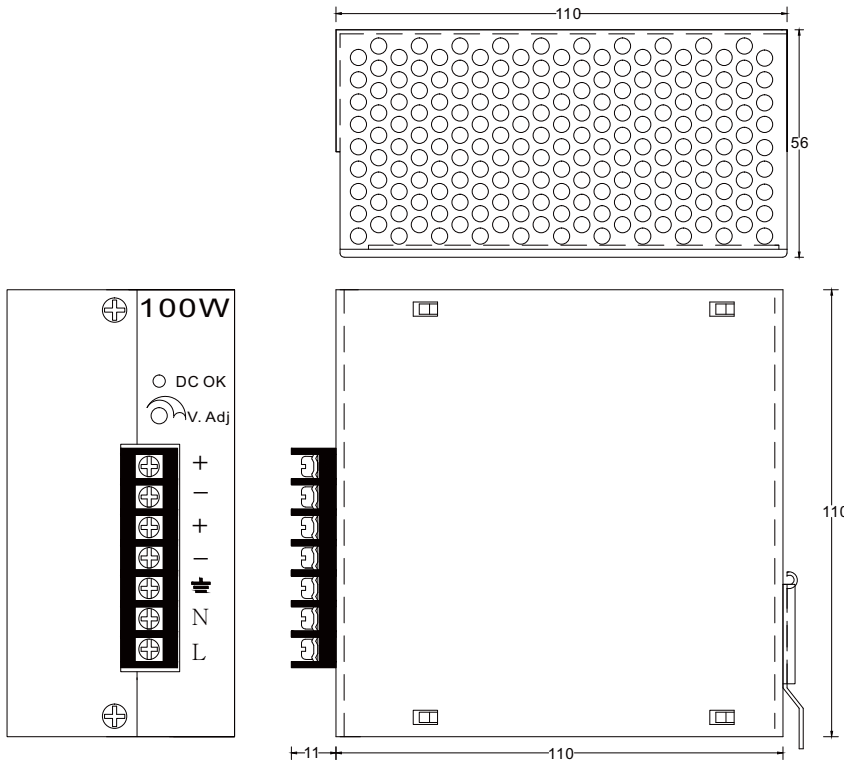

Case No.	AD072	
Dimensions	121(D)x56(W)x110(H)mm	
Case Material	Metal	
Weight	AD1100-12F	595.6 g
	AD1100-24F	607.2 g
	AD1100-48F	594.8 g

Terminal Allocation

Designation	Description
DC OK	Green LED Indicator
V Adj.	O/P Voltage adjustment
+	Output Positive
-	Output Negative
⊕	Earth
N	Input Neutral
L	Input Line

Installation instruction

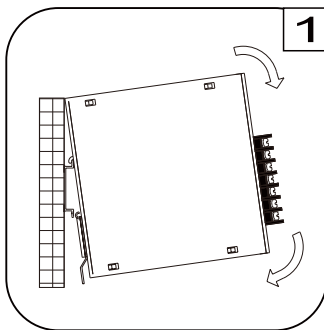

Place the top of the AD1100F rail mount over the top of the DIN rail. Tilt the bottom of the AD1100F toward the DIN rail until it snaps into place.

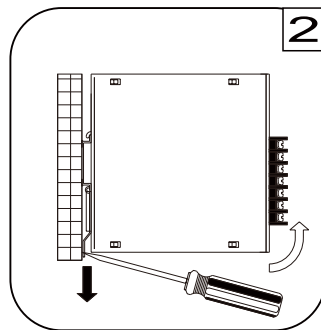

To remove the AD1100F from the DIN rail, use a flathead screwdriver to pull down the bottom of the rail mount and tilt it away from the DIN rail.

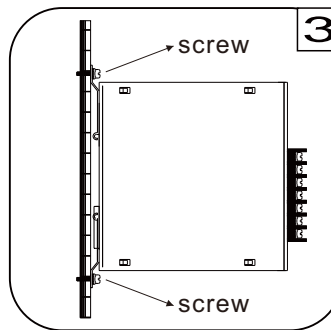

To install AD1100F on wall/plate, loosening screws on mounting bracket and pull both brackets out first. Then re-screwing the two brackets with screws onto wall/plate.

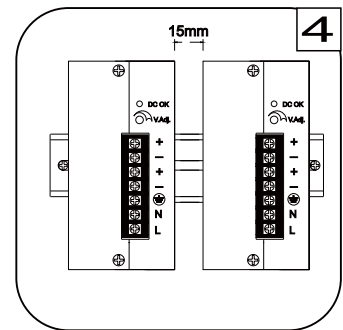

The left housing of AD1100F is designed as a heat sink, please keeping a minimum distance of 15mm from each other.